



# **Bending Welded Wire Reinforcement for Reinforced Concrete**

# Bending Welded Wire Reinforcement for Reinforced Concrete

## 1. Chapter One

Introduction .....	1
--------------------	---

## 2. Chapter Two

Equipment.....	4
----------------	---

## 3. Chapter Three

WWR Bend Detailing.....	9
-------------------------	---

## 4. Chapter Four

Pre-Bent WWR as a Labor Reducer .....	14
---------------------------------------	----

## 5. Chapter Five

Representative Applications.....	16
----------------------------------	----

## 6. Disclaimer

*This publication and its contents, including, but not limited to, textual material, graphs, tables, charts, calculations, statistics, photographs and/or drawings are made available by the WRI "AS IS" and as an informational resource only. WRI, its officers, directors, employees, agents, contractors, volunteers, members and consultants DISCLAIM ANY AND ALL EXPRESS AND IMPLIED WARRANTIES, CONDITIONS, REPRESENTATIONS, OR OTHER TERMS (INCLUDING AS TO SATISFACTORY QUALITY, FITNESS FOR A PARTICULAR PURPOSE, SUITABILITY OR MERCHANTABILITY) with respect to the publication and its contents. To the fullest extent permitted by applicable law, WRI fully disclaims any and all liability or responsibility for any damages, injuries or losses to persons, property, or business, including, but not limited to, lost profits, direct, indirect, incidental, consequential or punitive damages, costs, and expenses, including attorneys' fees and court costs, arising out of, or related to the downloading and/or use of this publication and its contents.*

# Introduction



Where construction requires the bending and shaping of reinforcement, welded wire reinforcement has been relied upon as a code-accepted structural solution that is characterized by faster and more economical production. Hydraulic bending equipment simplifies the production of reinforcement cages made from mats of welded wire, with the ability to execute multiple, sequential bends on a common sheet in a plant-controlled environment, resulting in a ready-to-place assembly with tight tolerances. The fabrication and placement of large sections of reinforcement made from welded wire reinforcement provides optimum use of labor and simplifies project supervision and inspection.

Formed into shapes that include applications such as beam stirrups, column ties, slab and wall mats, box culverts, and footing reinforcement, welded wire has increased savings in placement time in both precast and cast-in-place construction. For elevated slab and beam construction, contractors optimize allocation of labor resources by utilizing hooked-termination flexural WWR mats and WWR beam stirrup cages in lieu of individually placed bars. For utility vaults and box culverts, precasters cut assembly time by using pre-bent WWR mats for combined slab and wall reinforcement. Bent WWR mats are also regularly leveraged as stem and flange reinforcement in long-spanning precast prestressed bridge girders, where the WWR can be confidently positioned without concern over shifting or racking during tensioning and concrete placement.

In planning your next project, consider the advantages of bent welded wire reinforcement as outlined in the following pages.



**Figure 1.1: Bent WWR in a casting bed for a precast prestressed highway bridge girder**



**Figure 1.2: Bent WWR in a casting bed for a precast prestressed highway bridge girder**

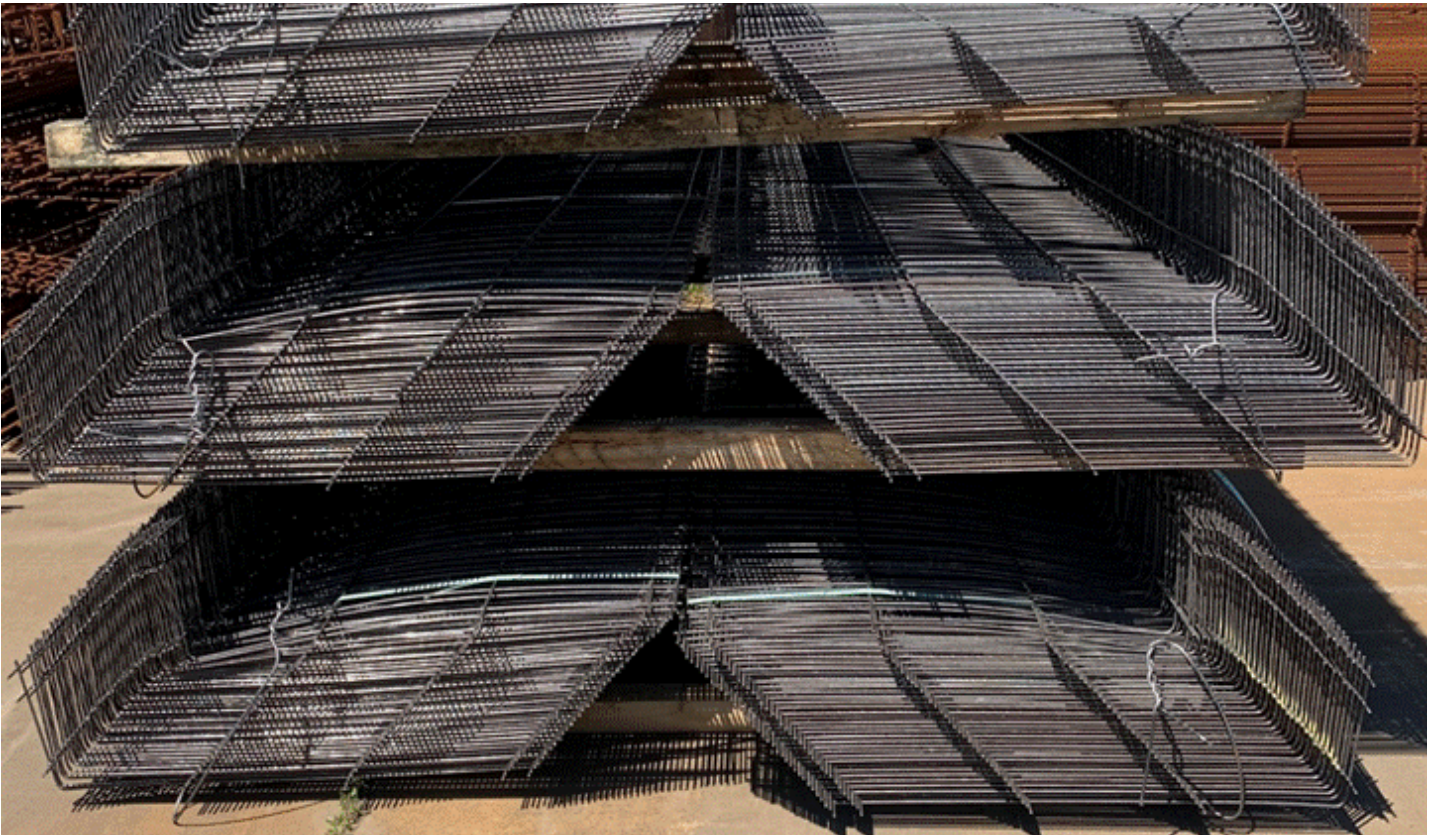

**Figure 1.3: Bundles of bent WWR staged on the manufacturer’s yard in preparation for loading and shipment**



**Figure 1.4: Bundles of bent WWR staged on the manufacturer’s yard in preparation for loading and shipment**

## Chapter Two

# Equipment

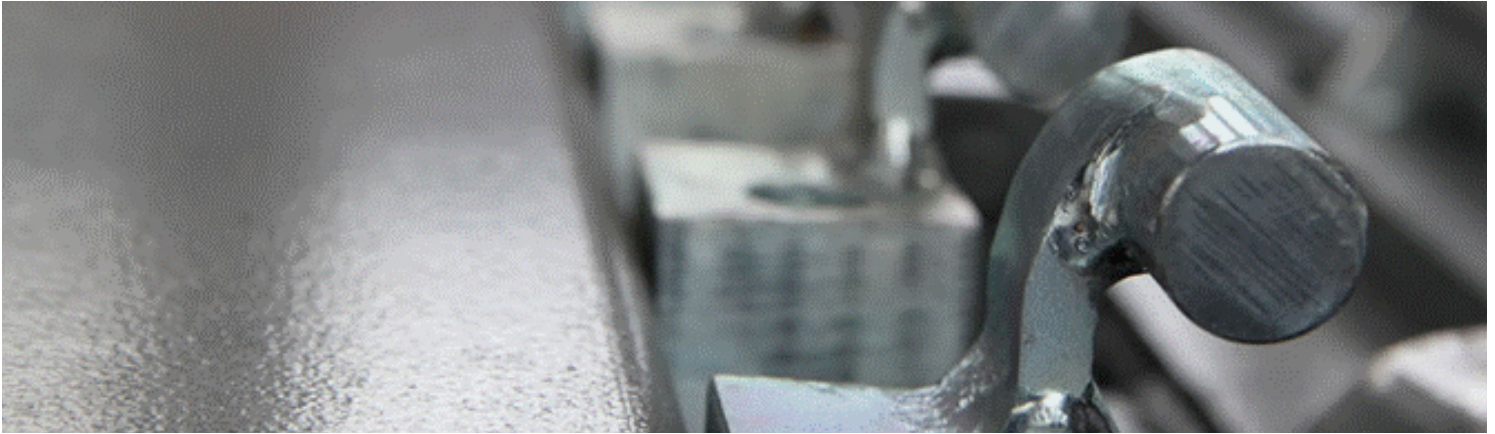

**Figure 2.1:** A close-up view of mandrels on a bending machine. The mandrels are positioned to align with a WWR mat's wires being bent by the manufacturer.

The fabrication of welded wire reinforcement into various structural shapes is readily accomplished with two basic pieces of portable equipment: a bending machine and a cutting device, each of which operates on electric power.

The bending machine provides the flexibility of adjusting to various wire spacings, angles of bend, and bending radii. This equipment is manufactured in sizes ranging in length from 8 to 40 feet. Capacities range from small wire sizes to heavy structural wires up to 3/4" diameter. The mats of welded wire are bent on the machine by a continuous rail which rotates through an angle of 0° to 180°, shaping the wires around the circular mandrels. This rail can be preset to stop at any angle; additionally, both the mandrel size and positioning are adjustable, allowing for variation in diameter and spacing along the length of the mat as required to meet the design requirement for bend radius and wire layout.

The portability of bending equipment is an attribute often taken advantage of by contractors on large, high-volume projects where the cost benefit analysis justifies the bending operation to be on site. Depending on the spatial characteristics of a bent item and the resulting displaced volume of multiple items nested and placed on the flatbed trailer, the transport of bundles of flat (non-bent) mats with subsequent bending on-site is often a more cost-effective option. The more densely occupied with product a trailer's freight volume is (e.g., shipping more steel than air), the fewer truck loads are required to get the product to the job. Not only does this result in a savings on cost of freight, but it can also improve process predictability and conformance with critical path milestones by removing potential delays related to truck availability and on-road incidents. Manufacturers commonly assist contractors with initial onsite equipment setup and provide the necessary real time instruction to facilitate smooth execution of the field bending operation.

Cutting equipment can be a simple electric-powered hand tool capable of cutting one wire at a time or larger powered equipment which cuts the full width of a sheet in one operation. This powered equipment allows the use of more economically manufactured sheets of wire reinforcement. Similar to bending equipment, cutting equipment is also portable and made available to contractors for on-site use.

Whether at the plant or carried out on site, the bending and cutting equipment are comparatively low-cost investments which require no special skills for efficient and consistent operation. Refer to Figures 2.2 through 2.8 for snapshots of a typical WWR bending operation.



**Figure 2.2: Bending Operation Step 1 – the flat WWR mat is loaded on the bender with wires to be bent aligned with the mandrels. The interchangeable mandrels are sized and spaced to suit.**



**Figure 2.3: Bending Operation Step 2 – With the WWR positioned firmly, the operator enters the required bend angle at the control end of the machine, and the hydraulically-driven continuous rail contacts the WWR mat, creating a pushover effect. Because the WWR is secured so as not to be dislodged from the mandrels, cold bending of the wires results as the continuous rail starts to rotate through the programmed bend angle.**



**Figure 2.4: Bending Operation Step 3 – the rotation of the continuous rail terminates at the programmed angle to achieve the specified 90-degree bend angle.**



**Figure 2.5: Bending Operation Step 4 – The operator resets the machine so that the continuous rail is “zero’d out”. This WWR mat is to receive two (2) 90-degree bends, so the bending crew re-position the mat so that the mandrels make contact at the precise location where the second bend is to be executed.**



**Figure 2.6: Bending Operation Step 5 – With the WWR again secured, the bending process is repeated, with the continuous rail making contact with the wires to create a pushover effect resulting in a permanent cold bend.**



**Figure 2.7: Bending Operation Step 6 – with both 90-degree angles successfully achieved, the machine is turned off and the bending crew slides the WWR mat in a longitudinal direction in order to dislodge the wires from contacting the mandrels, at which point the mat can be lifted and removed from the bender.**

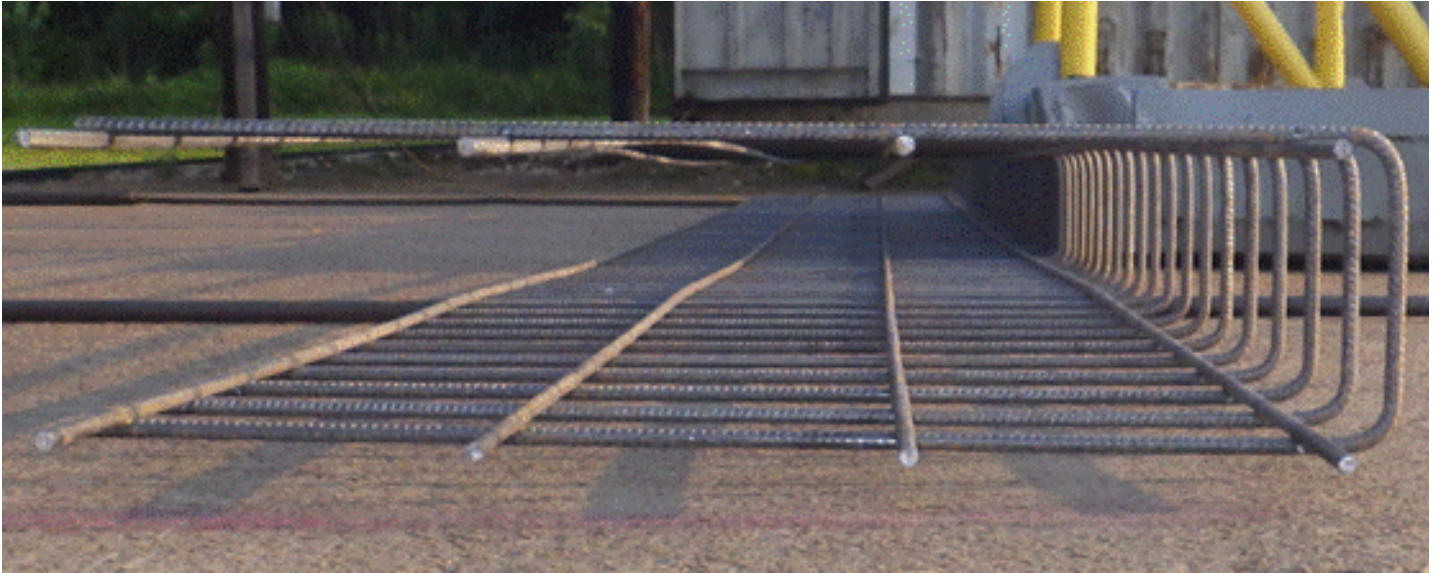

***Figure 2.8: Bending Operation Step 7 – the finished product is shown here, comprised of a two-bend configuration commonly used in highway barrier rail.***

# WWR Bend Detailing



Bending fabrication is defined in explicit detail on a bend drawing. A bend drawing not only communicates internally to the bending crew all relevant geometric constraints to ensure the fabricated product's alignment with established reinforcement and construction tolerance limits, but it is also presented as part of the reinforcement submittal subject to the designer's review and acceptance as it relates to conformance with design intent.

The following publications serve as guides for bending and finished dimensions of welded wire reinforcement:

- a. ACI 117 *"Specification for Tolerances for Concrete Construction and Materials"*
- b. ACI 318 *"Building Code Requirements for Structural Concrete"*
- c. ACI 319 *"Structural Precast Concrete"*
- d. ASTM A1064 *"Standard Specification for Carbon-Steel Wire and Welded Wire Reinforcement, Plain and Deformed, for Concrete"*
- e. CRSI *"Manual of Standard Practice"*
- f. CRSI ETN-M-12-19 *"Measuring Fabricated Steel Reinforcing Bars"*
- g. WRI *"WW-500 Manual of Standard Practice"*

In addition to the above, it is not uncommon for a manufacturer's customer – depending on their participation in and oversight of the reinforcement placement process – to request project or application-specific tolerances that are more stringent than those supported by the referenced standards. As a courtesy, welded wire reinforcement manufacturers will in some instances make adjustments to suit the customer's defined tolerance limits, but it must be understood that the manufacturer's tolerance obligation does not extend beyond that which is defined in the above documents. The communication of need for project-specific tolerances is incumbent on the customer, just as the reciprocal communication of the level to which these tolerances can be achieved is incumbent on the manufacturer/fabricator.

For the purposes of satisfying the design professional's intent – the primary factors of which are feasibility of bending the reinforcement without breakage and avoidance of crushing the concrete inside the bend – the following table outlines minimum inside bend diameters established by ACI 318 and enforced at the plant level by welded wire reinforcement manufacturers.

Minimum Inside Bend Diameters (to nearest 1/4" inch)			
Hooks for development of deformed Or plain wires in tension (adopted by WRI based on ACI requirements for reinforcing bars)		Deformed or plain wires used as stirrups or ties (ACI prescriptive requirements)	
6d <sub>b</sub> for all wires		4d <sub>b</sub> for wires > D6.0 (W6.0) 2d <sub>b</sub> for wires ≤ D6.0 (W6.0)	
W2.0	1.00"	0.50"	W2.0
W3.0	1.25"		W3.0
D4.0 (W4.0)	1.50"		D4.0 (W4.0)
D5.0 (W5.0)	1.75"	0.75"	D5.0 (W5.0)
D6.0 (W6.0)			D6.0 (W6.0)
D7.0 (W7.0)	2.00"	1.25"	D7.0 (W7.0)
D8.0 (W8.0)			D8.0 (W8.0)
D9.0 (W9.0)	2.25"	1.50"	D9.0 (W9.0)
D10.0 (W10.0)			D10.0 (W10.0)
D11.0 (W11.0)			D11.0 (W11.0)
D12.0 (W12.0)	2.50"	1.75"	D12.0 (W12.0)
D13.0 (W13.0)			D13.0 (W13.0)
D14.0 (W14.0)	D14.0 (W14.0)		
D15.0 (W15.0)	D15.0 (W15.0)		
D16.0 (W16.0)	2.75"	2.00"	D16.0 (W16.0)
D17.0 (W17.0)			D17.0 (W17.0)
D18.0 (W18.0)			D18.0 (W18.0)
D19.0 (W19.0)			D19.0 (W19.0)
D20.0 (W20.0)	3.00"	2.25"	D20.0 (W20.0)
D21.0 (W21.0)			D21.0 (W21.0)
D22.0 (W22.0)			D22.0 (W22.0)
D23.0 (W23.0)			D23.0 (W23.0)
D24.0 (W24.0)	3.25"	2.50"	D24.0 (W24.0)
D25.0 (W25.0)			D25.0 (W25.0)
D26.0 (W26.0)			D26.0 (W26.0)
D27.0 (W27.0)			D27.0 (W27.0)
D28.0 (W28.0)	3.50"	2.75"	D28.0 (W28.0)
D29.0 (W29.0)			D29.0 (W29.0)
D30.0 (W30.0)			D30.0 (W30.0)
D31.0 (W31.0)	3.75"	2.50"	D31.0 (W31.0)
D31.0 (W31.0)	4.00"	2.75"	D31.0 (W31.0)
W45.0	4.75"	3.25"	W45.0

**Figure 3.1: Minimum Inside Bend Diameters**

- Notes: 1. Wire increments between those indicated shall satisfy the requirements noted.
2. Table shows 1/4" increments. Bend diameters at smaller increments (for example, 1/8") are permitted provided ACI minimum inside bend diameters are still achieved. *Table shows 1/4" increments. Bend diameters at smaller increments (for example, 1/8") are permitted provided ACI minimum inside bend diameters are still achieved.*

The following information is an illustrative example of how a bend drawing is derived based on a design professional's contract drawing information for a post-tensioned parking garage beam.

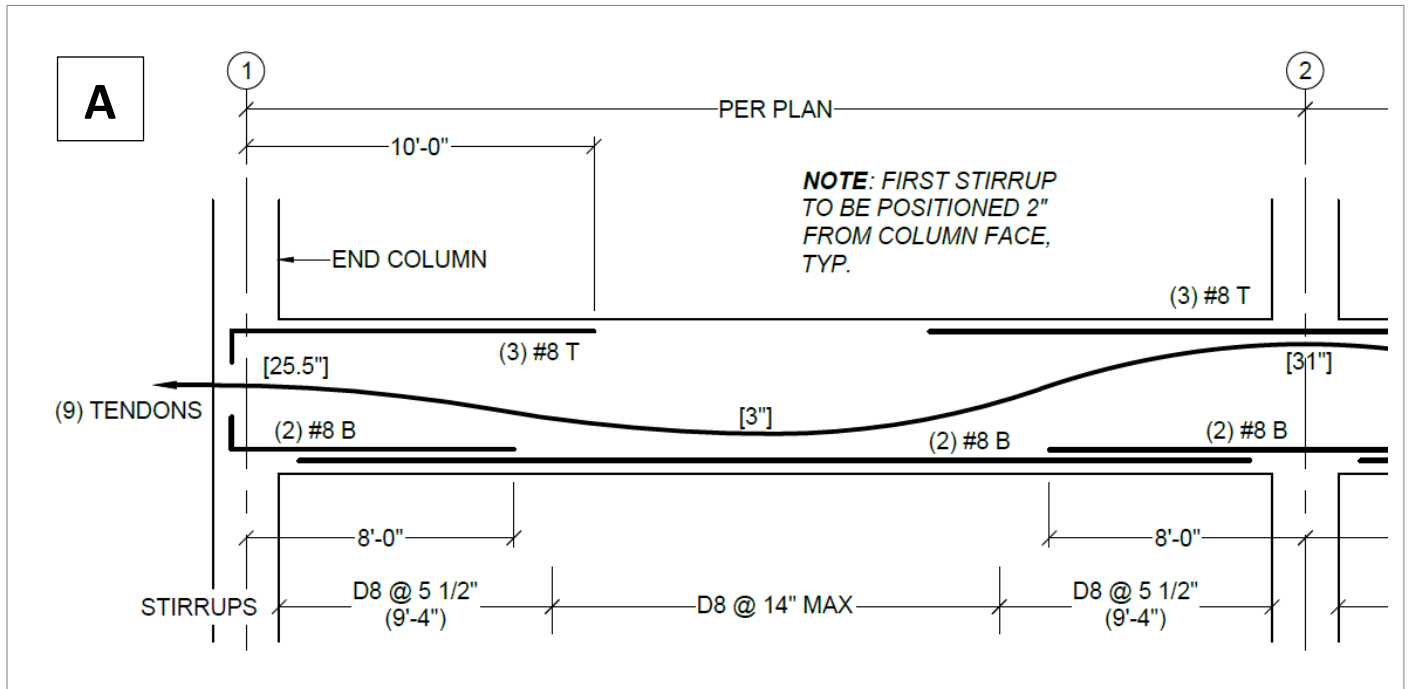

Figure 3.2: The engineer's contract drawings indicate deformed wire as an acceptable transverse reinforcement solution for a post-tensioned gravity beam.

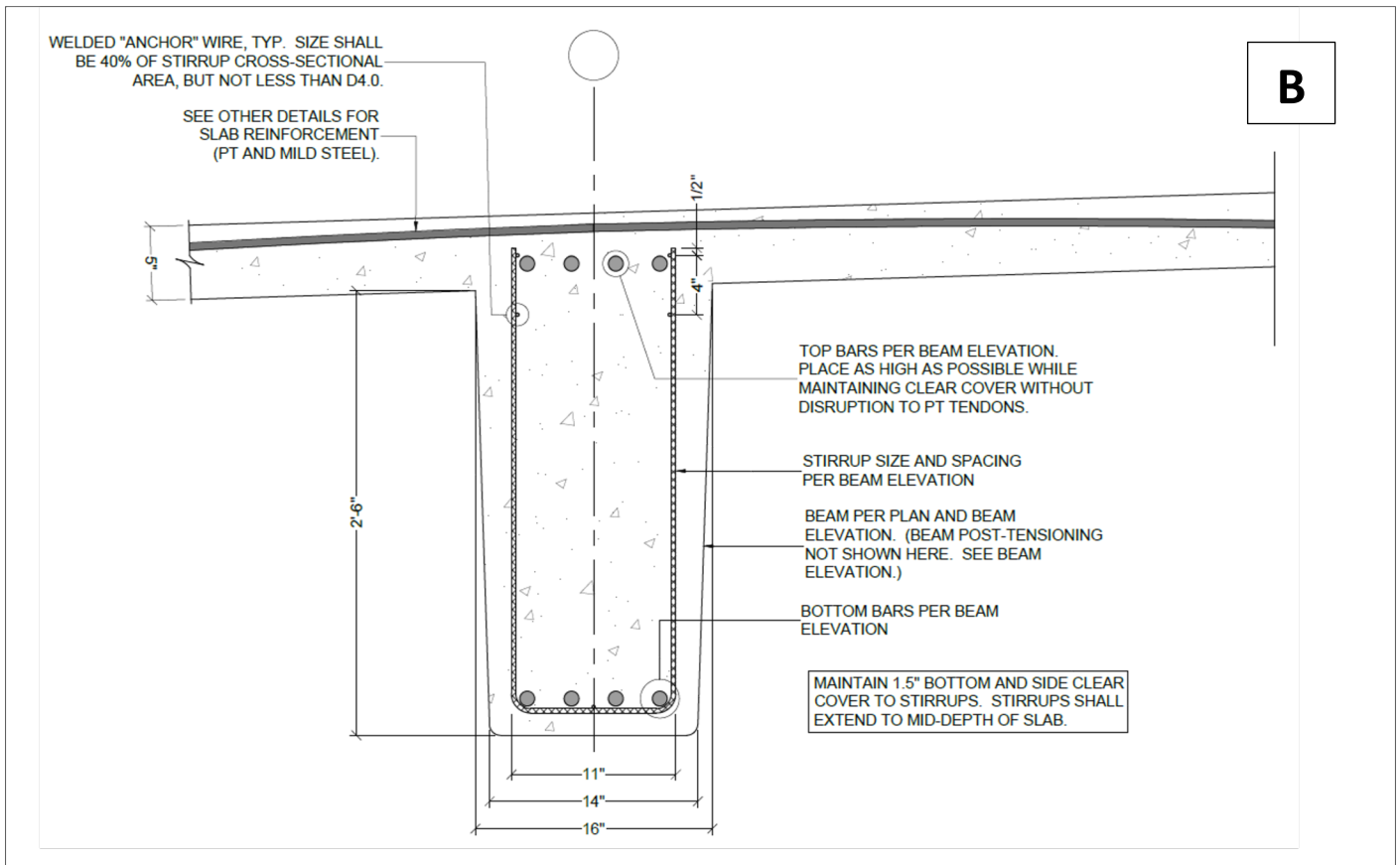
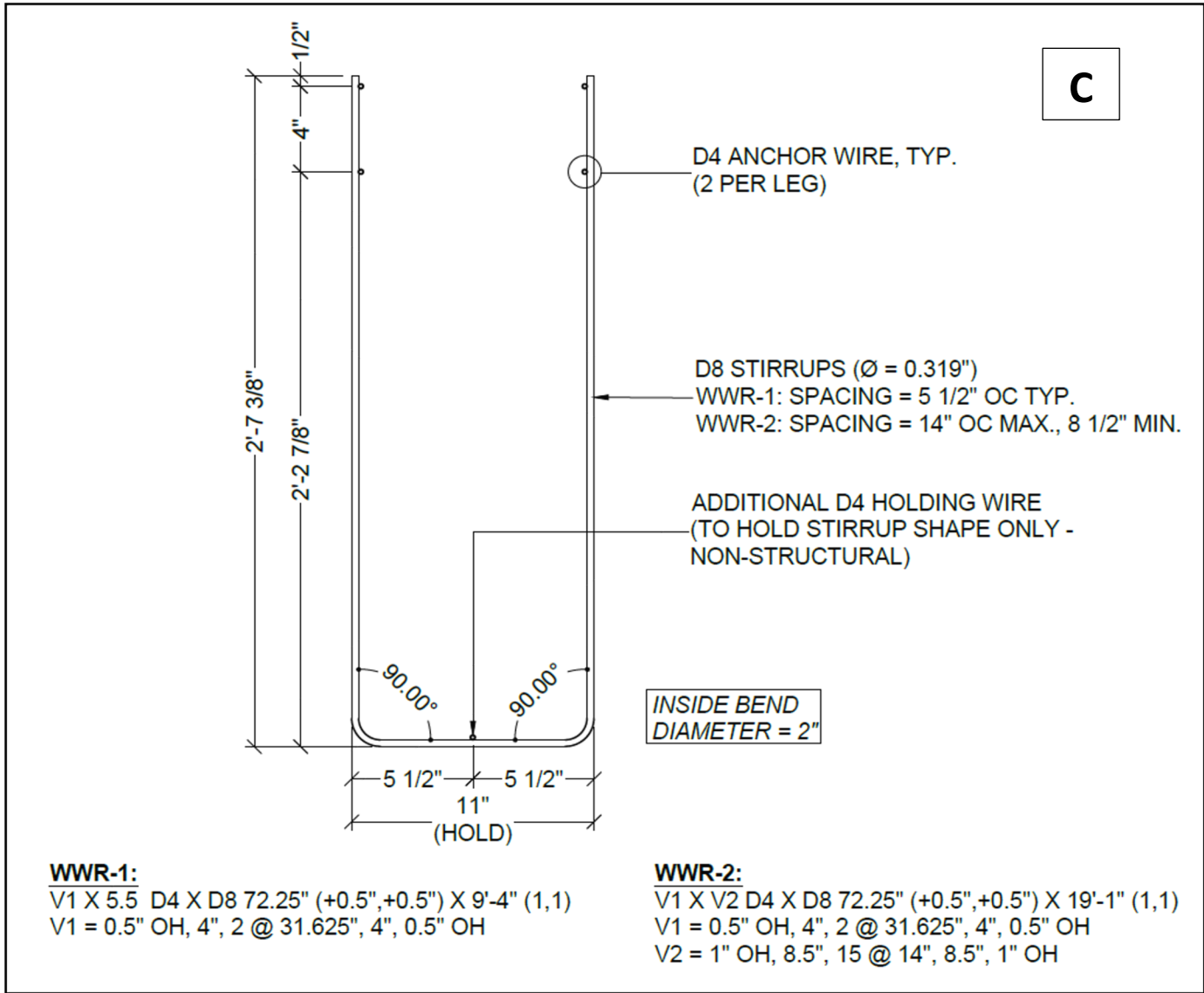

Figure 3.3: The engineer's contract drawings provide a WWR-specific section showing the U-stirrup with welded intersection curtailment in the compression zone. Sufficient structural geometry is furnished for the WWR detailer to derive the stirrup geometry itself.



**Figure 3.4:** A bend drawing suitable for internal manufacturing and Engineer-of-Record design intent review is prepared by the WWR detailer. This bend drawing represents two separate WWR mats required to satisfy the full-length arrangement of transverse reinforcement for the gravity beam.

Specific attention is drawn to the bend angles and the inside bend diameters to show conformance both with the engineer's design intent and the prescriptive ACI 318 requirements. Note that the inside bend diameter selected by the manufacturer is larger than the ACI-prescribed minimum, an acceptable variation that is likely driven by the manufacturer's available standard-sized mandrels.

Also note the WWR detailer's identification of a critical "hold" dimension where the base of the stirrup is to be positioned in the form to maintain 1.5" clear side cover, as well as permissible fabrication tolerances. Not unlike loose reinforcing bars, depending on a number of factors related to the interface between the reinforcement and the mandrel about which it is bent, there is a natural wire length elongation/gain component that the WWR designer and detailer must account for and control based on plant-specific bending equipment parameters (friction, slip, mandrel wear & tear, etc.) and past experience.

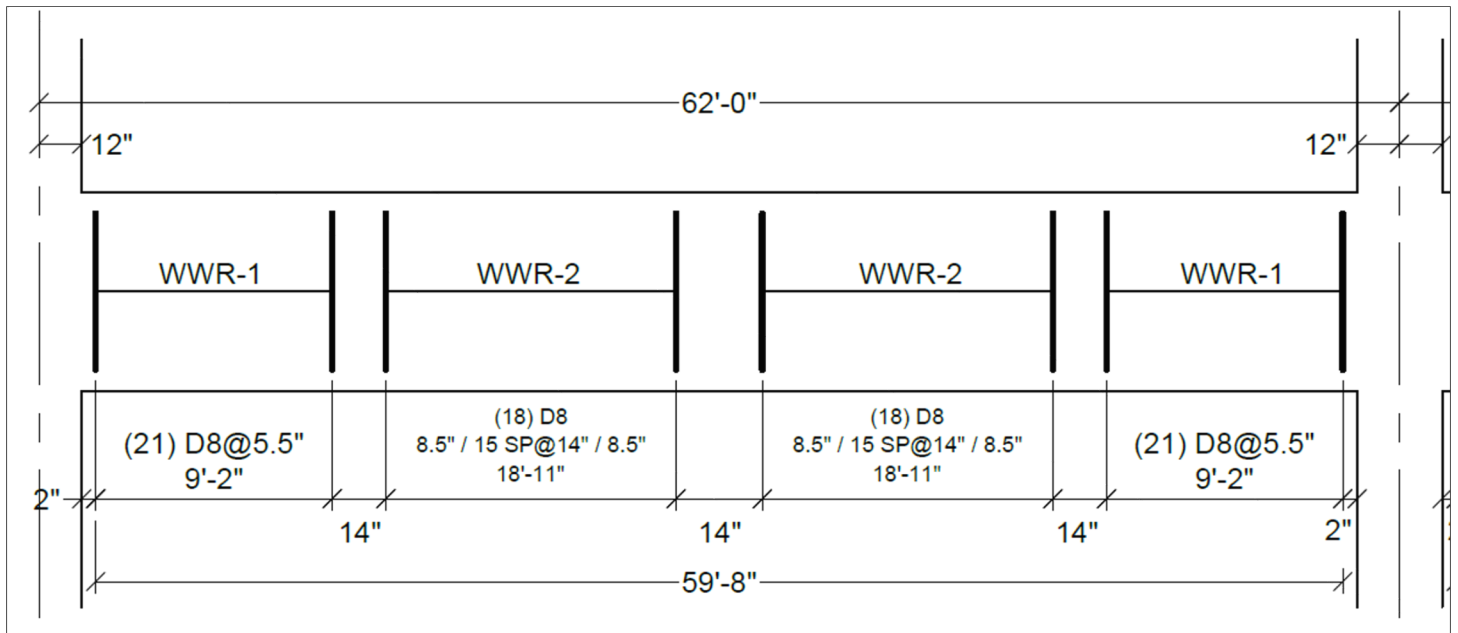

**Figure 3.5:** A required accompaniment in the project reinforcement submittal issued for the Engineer of Record's review is a placement view showing how the WWR cages are to be positioned within the structural element. Note that the WWR detailer generated WWR cage styles that maintained the engineer's defined spacing (14" on center) so that the placement crew would not have to keep track of atypical spacing/offset dimensions along the beam length. Also note that while WWR-1 is comprised of uniformly spaced stirrups, WWR-2 utilizes a variable spacing as required to cover the defined reinforcement extents. Variable spacing of wires on a common mat is commonplace and, given modern equipment capabilities and manufacturing procedures, can be taken advantage of without any additional cost premiums when compared to mats with uniformly spaced wires.

# Pre-Bent WWR as a Labor Reducer

Bending welded wire fabric literally adds a third dimension to concrete reinforcement. The welded wire mats can be bent to the shape required to occupy a structural element's length or coverage area, with the benefit of modular-style installation of combined units of reinforcement. This approach to on-site installation of reinforcement for structural concrete manifests itself in pronounced labor and time savings, the latter of which is illustrated in Figure 4.1 for stirrup type applications (taken from a time-study carried out by Purdue University in the early 2000s).

The contractor's success is a direct function of workforce allocation efficiency and staying in front of the schedule's critical path.

Because of this, the implementation of welded wire reinforcement and its impact on the full construction phase life cycle continues to deserve close consideration by savvy builders.

Time and cost savings on the jobsite are a moot point if the installed assemblies themselves are not in conformance with their intended positioning in the structural element. This is perhaps where bent welded wire reinforcement assemblies shine the most: the tolerance control for placement of the reinforcement is essentially "built in". Reinforcement orientation and spacing - and the resulting clearances from formed surfaces - are attributes that are not only simplified for the placing crew, but the verification effort carried out by the design professional as part of their construction administration work and the jurisdictional inspector's code-mandated observation and documentation end up equally streamlined.

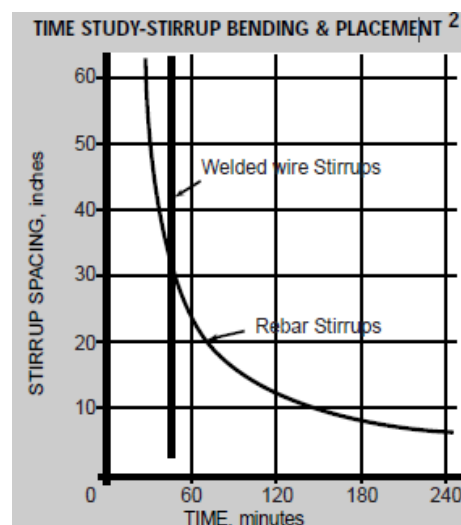

Figure: 4.1

Welded wire reinforcement's primary purpose has always been to provide a structural mild steel reinforcement that could be expeditiously installed over larger areas and/or lengths of the structure. With the added benefit of pre-bent reinforcement geometries, welded wire reinforcement is a solution that can be deployed in more complex structural spatial configurations, further reducing the manual effort required to achieve the engineer's design intent.

On a large scale, the construction labor shortage is a very real consideration as the built environment continues to expand. Contractors are more frequently leveraging automation and seeking labor alternatives due to an ever-decreasing pool of skilled construction workers. Advancements in modular building construction methods, robotics, and three-dimensional printing technology are indicators of the industry's acknowledgement of a shrinking workforce.

The global modular building construction market size valued at \$115 billion in 2018 is projected to reach nearly \$200 billion by 2026, growing at a compound annual growth rate of over 7% (Allied Market Research "Modular Construction Market Outlook", February 2020, Chinchane and Sumant). The modular construction business in the United States has doubled in size to \$8 billion between 2014 and 2019 (National Real Estate Investor "Modular Construction Use is 'Booming' in Commercial Building", May 2019, Obando). While not every single component of modular construction is comprised of reinforced concrete, the trend and intended outcome is what matters: increase prefabrication and minimize the impact of labor shortage.

According to McKinsey Global Institute, and as reflected in Figure 4.2, construction productivity has fallen by half since the 1960s (Forbes - "[The Construction Labor Shortage: Will Developers Deploy Robotics?](#)", July 2019, Cilia), leading to genuine interest in robotics as a solution to various vertical construction tasks.

Welded wire reinforcement is a code-compliant structural reinforcement that has a longstanding precedent for successful use in the construction industry. Its role in the modernization of the construction process continues to grow in large part due to the historical familiarity of the material (steel reinforcement for three-dimensional concrete in rod/wire form) and an installation process that is 100% scalable at the hands of a reduced-size placing crew using established and code-acknowledged methods.

There no doubt exists a certain novelty to an articulated robot tying together a single rebar cage or a specialized vehicle “printing” layers of concrete into a three-dimensional shape. These forward-thinking, manual labor-minimizing solutions may very well provide snapshots into the potential future of construction. As it relates to actionable solutions for today’s construction environment and beyond, however, the most effective solutions are generally a blend between leveraged automation and appropriate manual oversight. Welded wire reinforcement with bending fabrication completed at the plant prior to shipment already fits this bill.

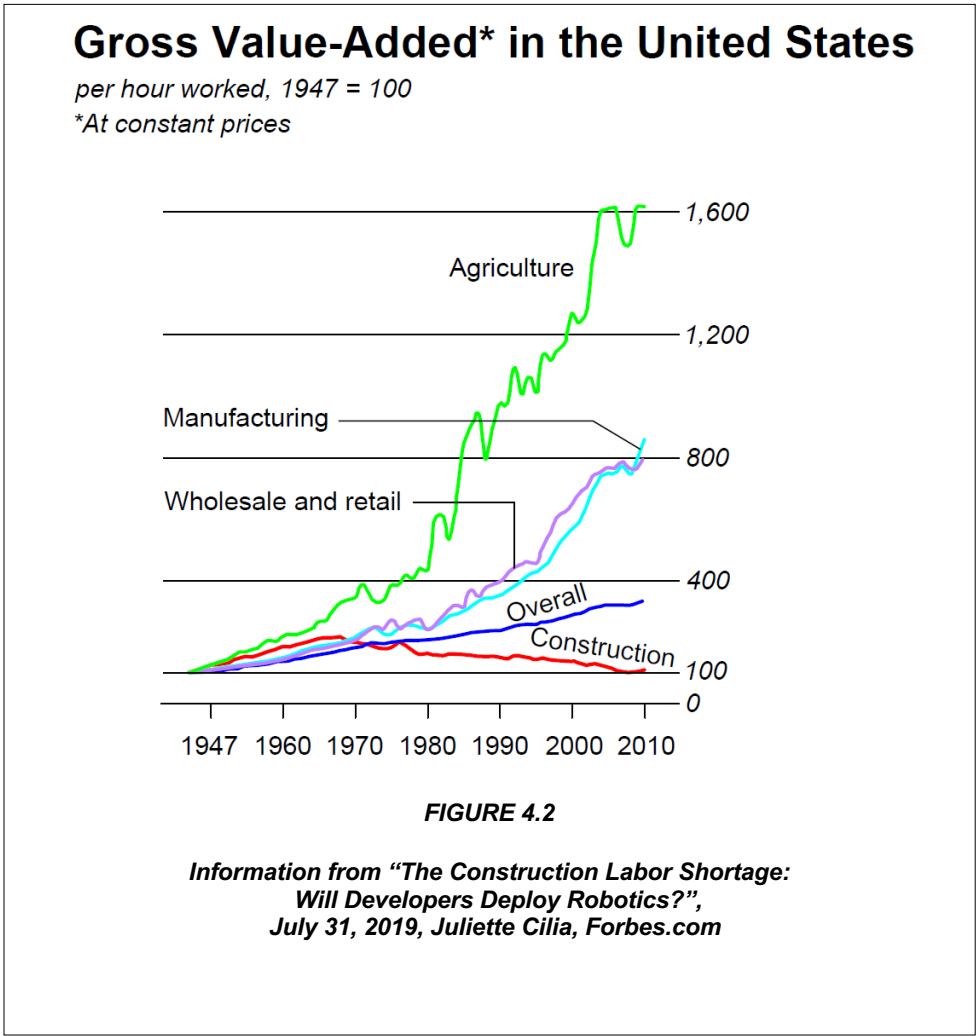

# Representative Applications

There exist a multitude of common bent reinforcement arrangements for which welded wire reinforcement is a tailor-made solution. It is important to keep in mind that, in addition to the select representative applications below, project-specific configurations requiring bent material can be evaluated on a case-by-case basis through collaboration between designer and producer, yielding much sought-after time and labor savings.

## Cast-in-Place Beam: U-Stirrup with Welded Anchorage

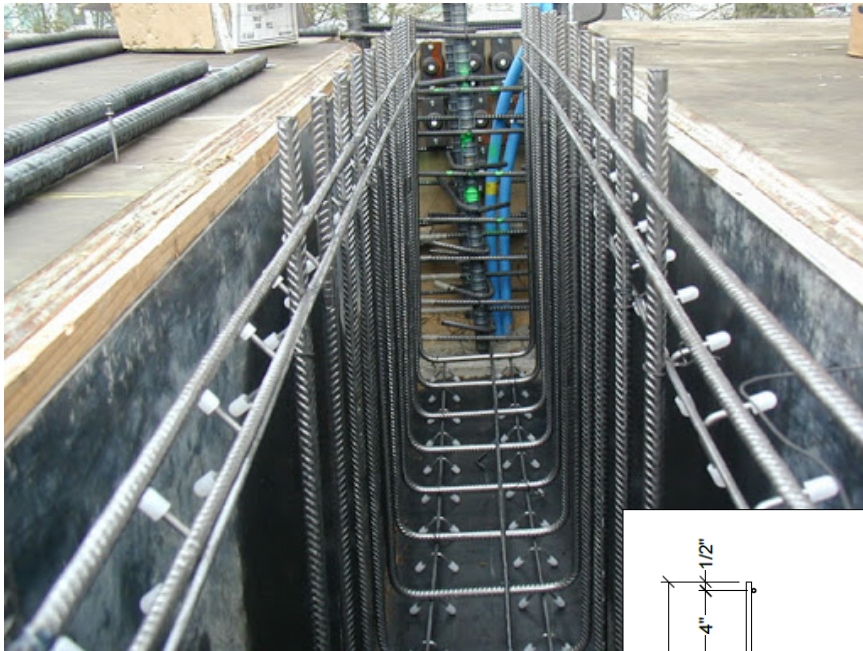

*U-stirrups are used in structural beams as transverse shear reinforcement and are typically comprised of two symmetrical 90-degree bends. The upper legs of the U-stirrup are furnished with anchorage wires, eliminating the need for hooked terminations in non-seismic beam applications.*

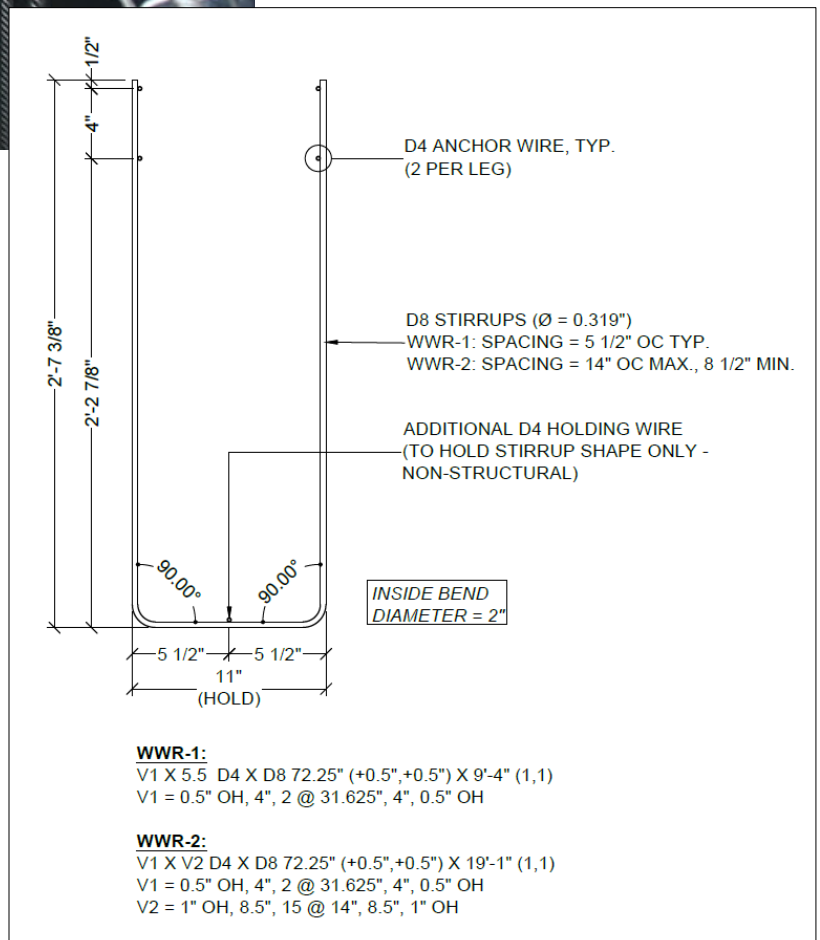

## Cast-in-Place Seismic Beam: U-Stirrup with Hooked Terminations



*U-stirrups with hooked terminations are used in structural beams as transverse shear reinforcement and confinement. These bent mats typically consist of two symmetrical 90-degree bends and two 135-degree "seismic hook" terminations on the stirrup legs. Hooked U-stirrups are used in conjunction with hooked cross ties (not shown) to form seismic hoops.*

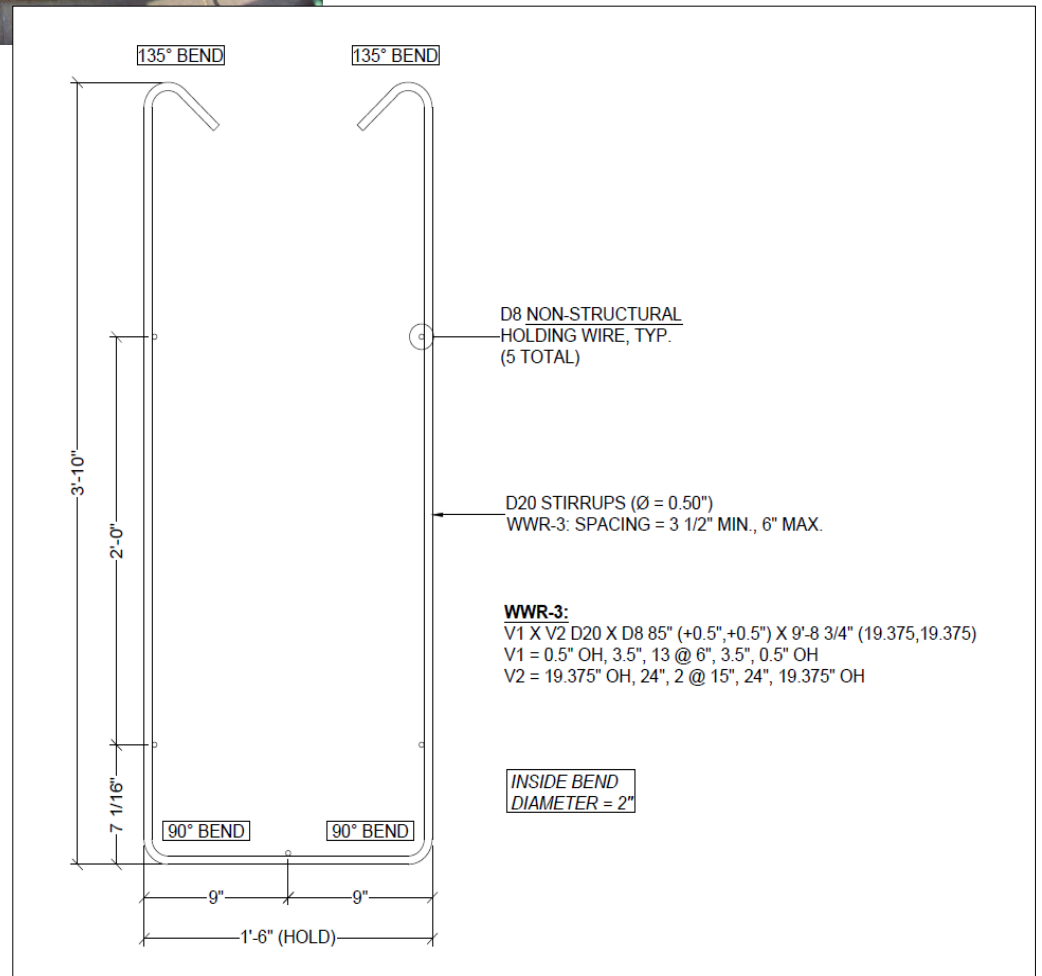

## Precast Stadium Risers – longitudinal and transverse steel



*Precast stadium risers utilize bent welded wire reinforcement in stepped configurations to satisfy mild steel requirements for shrinkage, temperature, flexure, and shear requirements. The mats consist of multiple consecutive bends that follow the stepped profile of the riser. Care is taken to position welded wire intersections to avoid interference at the bend locations.*

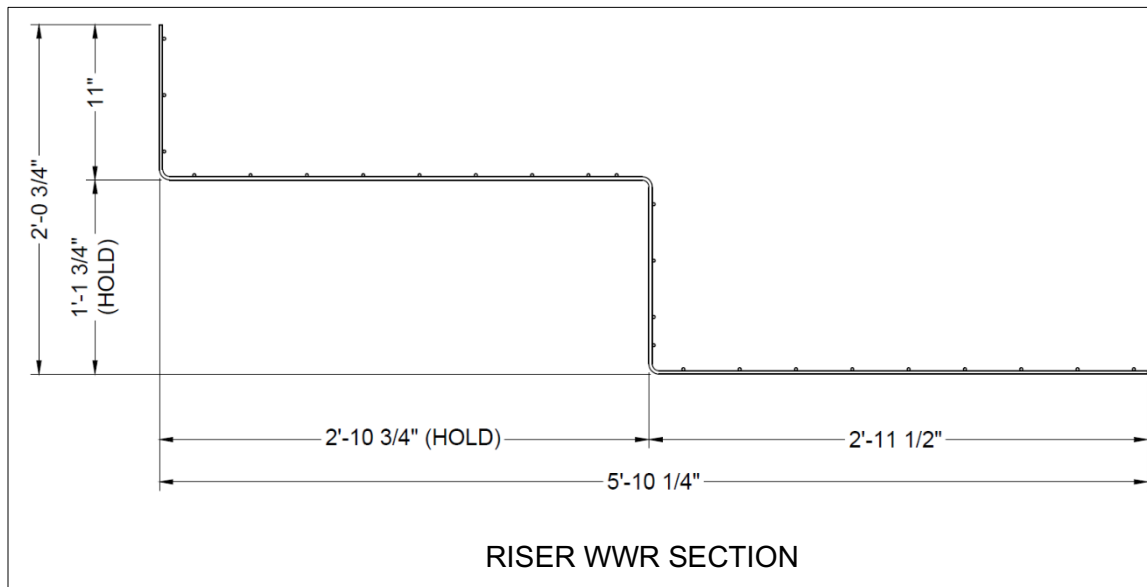

## Precast Box Culvert: Wall and Slab Reinforcement



*Precast box culverts rely heavily on bent welded wire reinforcement to provide the most efficient and cost-effective means of satisfying mild steel reinforcement requirements in the wall and slab elements. Welded wire reinforcement serves as the primary flexural and shrinkage/temperature steel.*

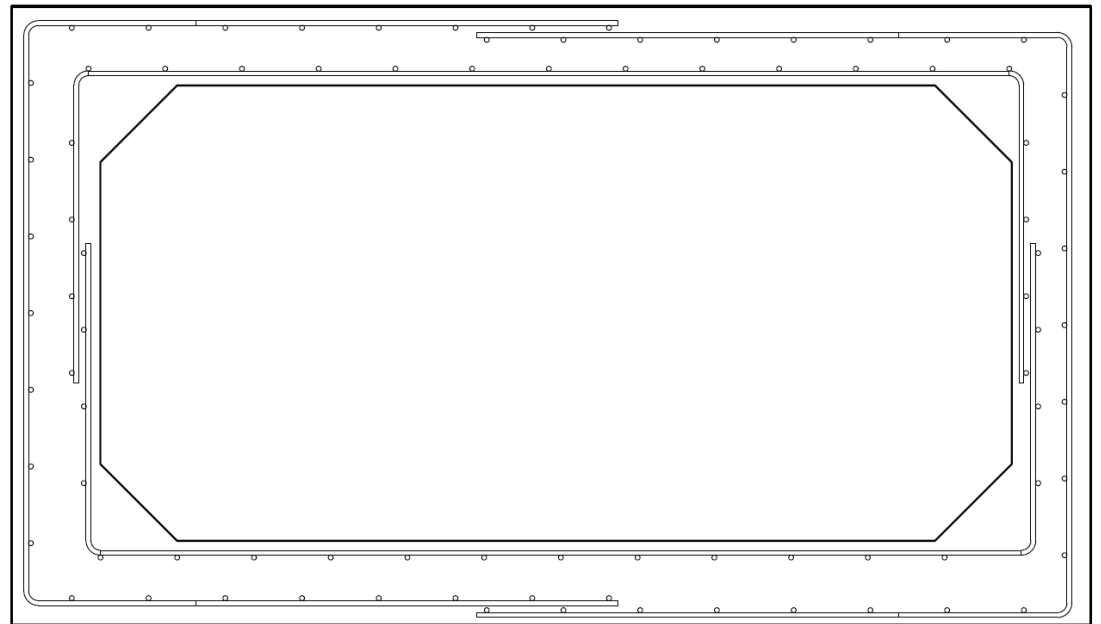

BOX CULVERT

# Precast Bridge Girder: Stems and Flange Reinforcement



*Welded wire reinforcement is used extensively in precast prestressed bridge girders for the purposes of flexural and shear resistance. Bent reinforcement applications exist for both flanges the vertical stem.*

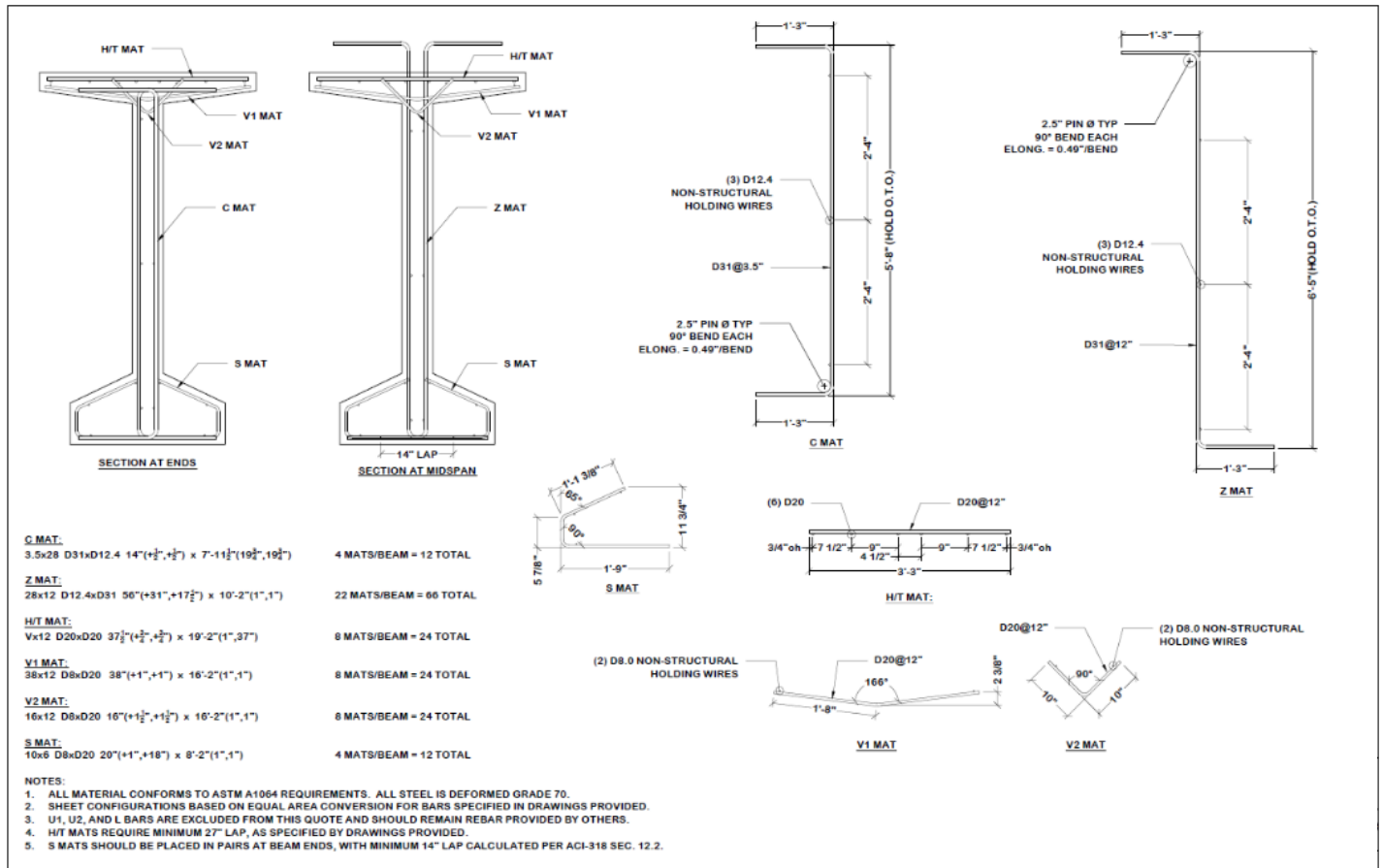

# Roadway and Bridge Barrier Rail – Impact Reinforcement

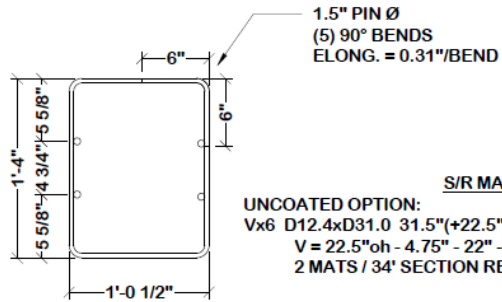
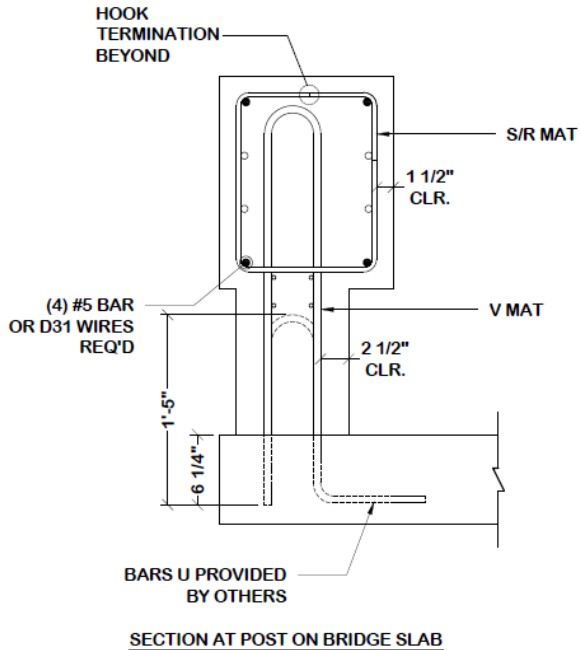

**S/R MAT**  
 UNCOATED OPTION:  
 Vx6 D12.4xD31.0 31.5"(+22.5",+11") x 17'-9"(1",14")  
 V = 22.5"oh - 4.75" - 22" - 4.75" - 11"oh  
 2 MATS / 34' SECTION REQ'D LAP = 21"

EPOXY COATED OPTION:  
 Vx6 D12.4xD31.0 31.5"(+22.5",+11") x 18'-7"(1",24")  
 V = 22.5"oh - 4.75" - 22" - 4.75" - 11"oh  
 2 MATS / 34' SECTION REQ'D LAP = 31"

(4) D31x33'-8" STRAIGHT & CUT WIRES / 34' SECTION REQ'D

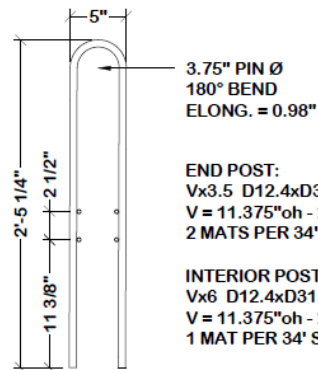

**V MAT**  
 END POST:  
 Vx3.5 D12.4xD31.0 37.5"(+11.375",+11.375") x 8'-7.5"(1",1")  
 V = 11.375"oh - 2.5" - 32.5" - 2.5" - 11.375"oh  
 2 MATS PER 34' SECTION REQ'D

INTERIOR POST:  
 Vx6 D12.4xD31.0 37.5"(+11.375",+11.375") x 3'-8"(1",1")  
 V = 11.375"oh - 2.5" - 32.5" - 2.5" - 11.375"oh  
 1 MAT PER 34' SECTION REQ'D

**NOTE:**  
 CONFIGURATION SHOWN IS TYPICAL FOR 34' CONCRETE PANEL LENGTH AT POST ON BRIDGE SLAB CASE WITHOUT THE 2" OVERLAY. THIS REPRESENTS THE MOST CONSERVATIVE REINFORCEMENT QUANTITY IN THE ABSENCE OF PROJECT-SPECIFIC PANEL LENGTH AND END POST LENGTH.

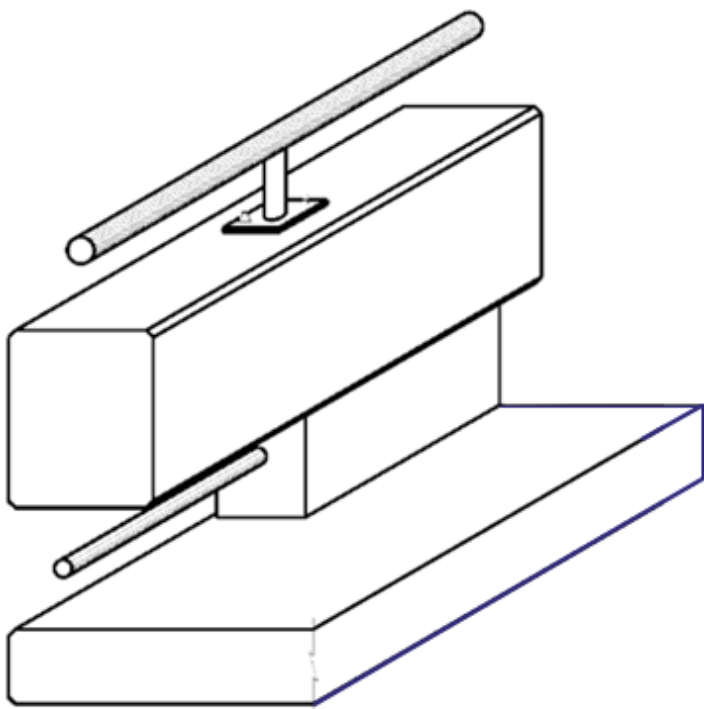

*Welded wire reinforcement is a natural fit for the broad spectrum of cast-in-place and precast barrier rail geometries tasked with containment and redirection of vehicular collisions. Shown here is a combination rail utilizing both a closed tie configuration in conjunction with a 180-degree hairpin assembly.*

For more information visit our website:  
[WireReinforcementInstitute.org](http://WireReinforcementInstitute.org)